

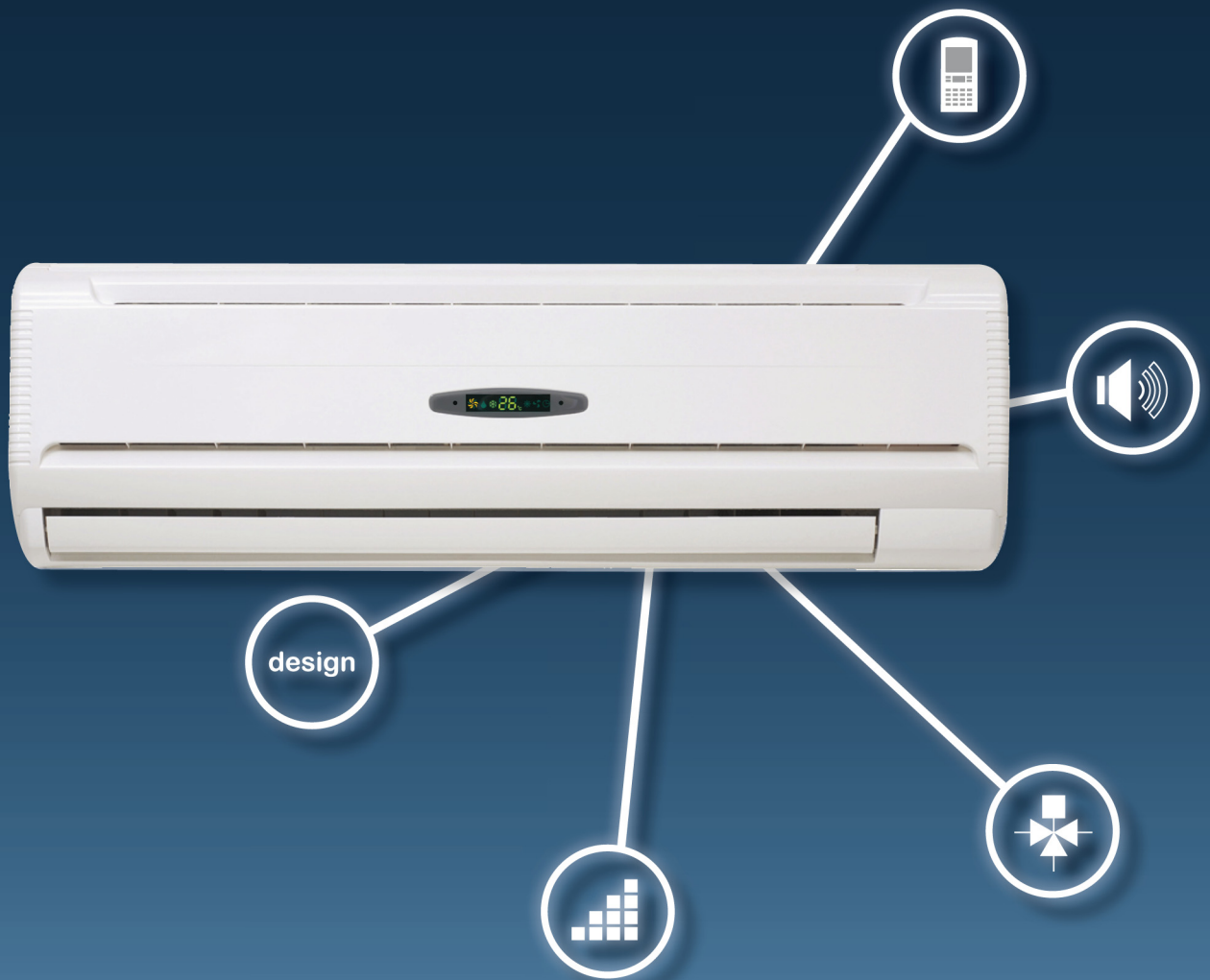

# TOUCH

## WALL WATER FAN COIL UNIT



design

  
1.24 kW  
4.00 kW

  
2.00 kW  
8.28 kW

  
234 m<sup>3</sup>/h  
620 m<sup>3</sup>/h



TOUCH

---

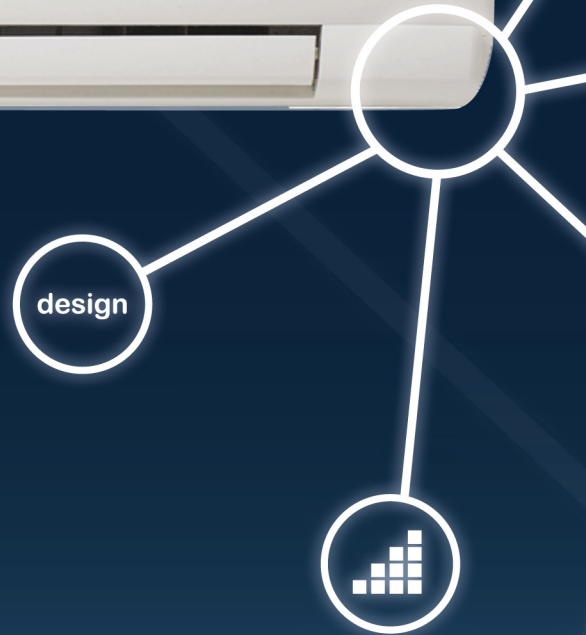

## **Quality and design: the new wall-mounted water fancoil touch**

With a tangential fan that offers the maximum acoustic comfort, the wall-mounted water fancoil units of the new range TOUCH are the ideal solution to be installed in residential and office buildings.

The modern aesthetics and the innovative technical features make TOUCH the ideal solution for quality and room enhancement.

### **Capacity regularity**

Thanks to the range with four different sizes, the new wall-mounted fancoil TOUCH allows to regularly cover capacities going from 1.2 kW to 4.0 kW

### **Attractive design**

An attractive design and modern shapes make TOUCH perfect to be installed in residential and office buildings where comfort and enhance of the environment are the most important aspects to be considered. TOUCH range is an extremely elegant product thanks to its aesthetic quality, innovations and top performances.

### **Acoustic comfort**

The dedicated study on the different speed of the units has allowed to reach very high performances with minimum noise levels.

### **Valve included**

An innovative solution that allows an easier installation and a reduced energy save.



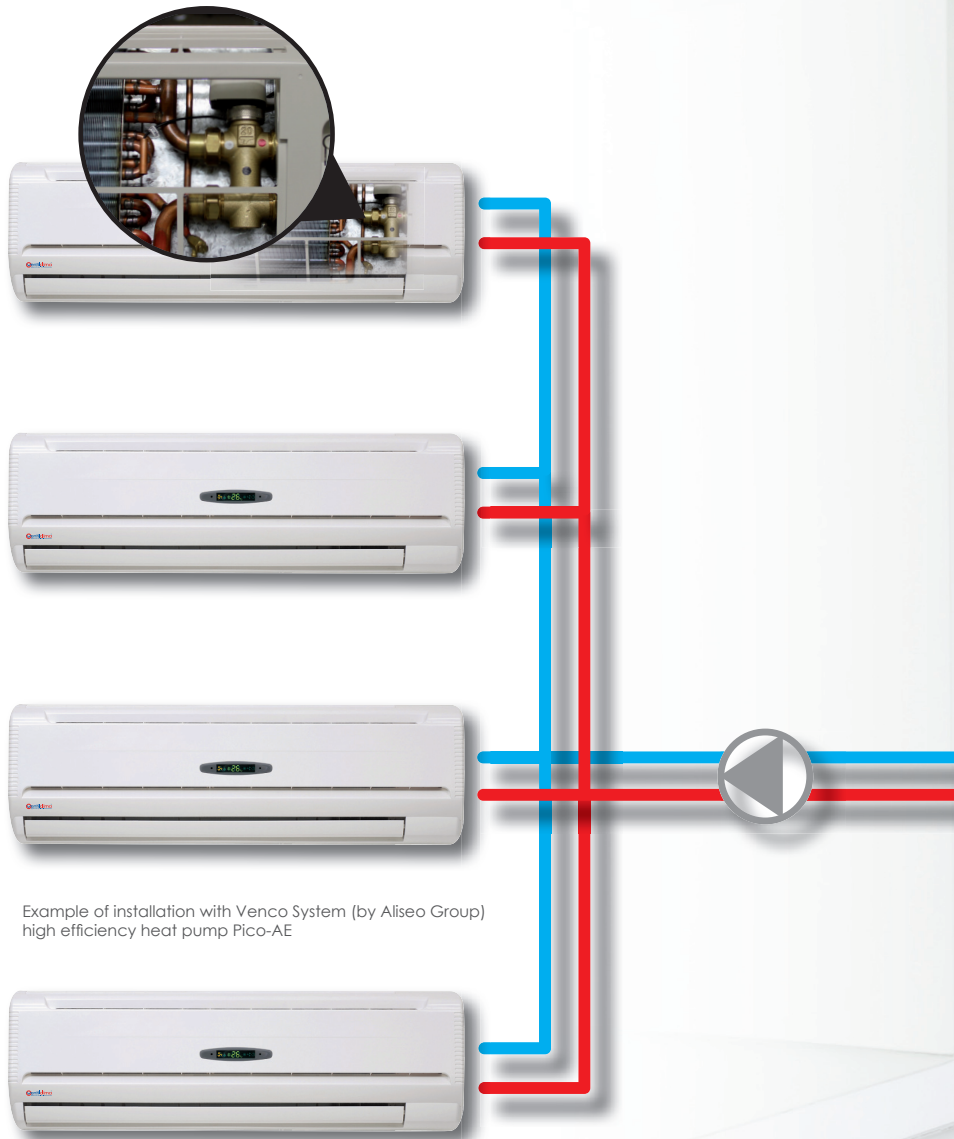

Example of installation with Venco System (by Aliseo Group) high efficiency heat pump Pico-AE



## Heat exchanger coil

With copper tubes and aluminium fins, the coil has a hydrophilic treatment that allows the condensate drops to slip into the drain pan ensuring an easier air crossing and more corrosion strength of the aluminium.

The air vent is easily reachable and it discharges directly in the condensate drain pan.

## Tangential fan

Designed to reach high capacities at low motor revolutions, the tangential fan guarantees a perfect union between silence and excellent performances.

## eco VALVE SYSTEM

Thanks to the integrated valve is possible to avoid efficiently the waste of energy, because the water flow is stopped when the unit is off, unlike normal split systems on which the flow remains even when the unit is not working.

This solution also ensure easy installation and maintenance, without requiring any niche in the wall.



### Remote control

Comfortable and intuitive, it has a minimal and ergonomic design that enhances its functionality and handiness.

### Automatic swing

With a simple click of the remote control you can have a complete control of the air flow to suit your needs and to ensure the maximum room comfort.

### Display



Integrated in the cover cabinet It shows the set-up of the unit: room temperature, fan speed and running mode.

### Sleep mode

This allows you a complete relax during sleep. Activating this mode the unit sets automatically temperature and fan speed to ensure the maximum comfort, noiselessness and low cost.

### Timer real time Programmable startup and shutdown

Thanks to this feature you can program (within 24 hours), the startup and shutdown of the unit, in a completely automatic way even in your absence, so that you will find the right room comfort at your arrival.

			1	2	3	4
	Total cooling capacity	W max	1960	2380	3340	4000
		W med	1730	2100	2960	3640
		W min	1550	1830	2420	2920
	Sensible cooling capacity	W max	1610	1900	2680	3130
		W med	1410	1640	2320	2850
		W min	1240	1410	1890	2260
	Water flow	l/h max	336	409	573	686
		l/h med	297	359	508	625
		l/h min	266	314	415	501
Water pressure drop	kPa max	15,9	22,9	14,8	21,6	
	kPa med	12,5	18,3	11,3	17,8	
	kPa min	10	14,3	9,7	11,8	
Heating capacity	W max	2570	2970	4390	4920	
	W med	2240	2610	3800	4450	
	W min	2000	2280	3000	3860	
	Water flow	l/h max	336	409	573	686
		l/h med	297	359	508	625
		l/h min	266	314	415	501
Water pressure drop	kPa max	15	20,5	17,3	19,8	
	kPa med	11,6	16,4	13,8	15,9	
	kPa min	9,3	13	8,3	10,6	
Heating capacity	W max	4390	5030	7480	8280	
	W med	3810	4400	6450	7500	
	W min	3390	3850	5070	6540	
	Water flow	l/h max	386	442	657	727
		l/h med	334	386	566	659
		l/h min	298	338	445	574
Water pressure drop	kPa max	18,4	22,4	21,1	21,2	
	kPa med	13,8	17,7	16	16,9	
	kPa min	10,9	14,1	8,8	13,1	
Air flow	m³/h max	344	417	553	620	
	m³/h med	282	333	476	544	
	m³/h min	234	273	375	426	
Sound power level	db(A) max	53	54	54	56	
	db(A) med	50	50	50	52	
	db(A) min	47	45	43	45	
Sound pressure level	db(A) max	45	45	45	48	
	db(A) med	41	41	41	44	
	db(A) min	38	37	34	37	
Power supply	230V 50Hz					
Power input	W max	29	29	48	51	
	W med	26	27	42	45	
	W min	25	25	35	35	
Absorbet current	A max	0,13	0,13	0,26	0,30	
	A med	0,12	0,12	0,22	0,24	
	A min	0,11	0,11	0,17	0,18	
Water content	L	0,81	0,85	1,24	1,85	

- **Standard unit with free outlet:** external static pressure = 0 Pa
- **Sound power level:** ISO 23741
- **Sound pressure level:** 8,6 dB(A) lower that the sound power level for a room of 90 m³ with a reverberation time of 0,5 sec.
- **Supported power supply:** ~230V±10% / 1ph / 50Hz



**COOLING**  
Inlet water temp.: 7°C  
Outlet water temp.: 12°C  
Inlet air temp.: 27°C d.b. - 19°C w.b.



**HEATING**  
Air temp.: 20°C  
Inlet water temp.: 50°C



**HEATING**  
Air temp.: 20°C  
Inlet water temp.: 70/60°C

			1	2	3	4
Dimensions	L	mm	880	990	1172	1172
	H	mm	298	305	360	360
	P	mm	205	210	220	220
Weight		kg	11.5	12.4	19	20.5

### GENERAL DIMENSIONS

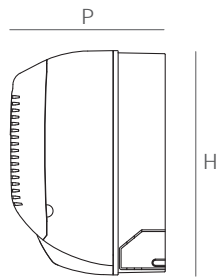

TOUCH 1-2

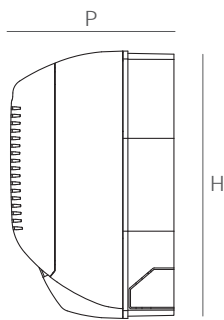
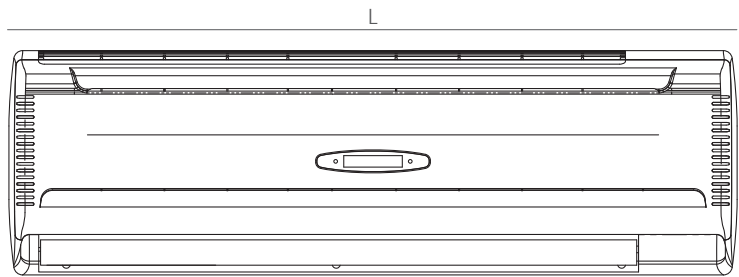

TOUCH 3-4

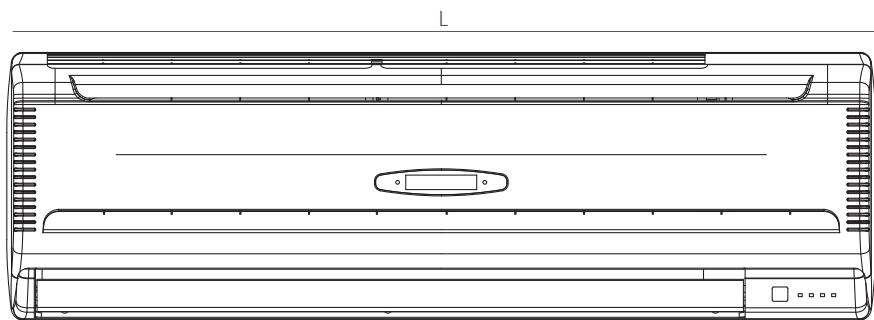

### HYDRAULIC CONNECTIONS AND CONDENSATE DRAIN

TOUCH 1-2

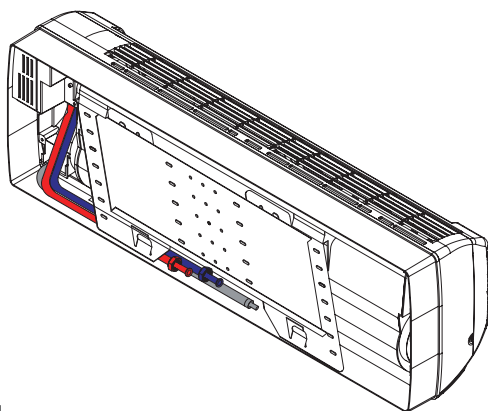

- Supply Ø 1/2"
- Return Ø 1/2"
- Condensate drain Ø 16.5 mm

TOUCH 3-4

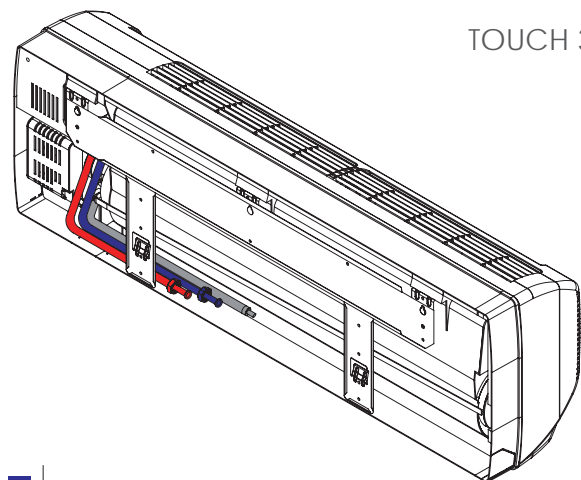

- Supply Ø 1/2"
- Return Ø 1/2"
- Condensate drain Ø 16.5 mm



[www.ventilclima.com](http://www.ventilclima.com)



ISO 9001:2000 - Cert. n. 1368